



DTE ENVIRONMENTAL FWC-3-10

The DTE Environmental in-vessel rotary composter is built for ease of operation and low maintenance. The composter is made with all stainless steel and synthetic components for long life and durability.

The FWC (Food Waste Composter) is part of our large offering of composting equipment and offers:

In-Feeding – Loading of the FWC is performed by dumping waste into the feed auger, which provides a premix feed into the unit. For the larger units, or if the unit were unattended for long periods of time, a hopper/mixer can be used to feed the FWC.

Air –Creating a negative pressure inside the FWC allows air to be drawn in through the vessel’s discharge. In doing so, it supplies needed air to the biological process as well as keeping odors from escaping. The air that is pulled through the unit is blown through a bio filter to eliminate odor and to de-humidify the air.

Sensing & Testing – Located under the full length access door there are three wireless temperature sensors and two product access covers. The covers allow for inspecting product in process. The PLC control allows for the temperature sensing of the product in the park position and also sensing of the air temperature for an optimized system.

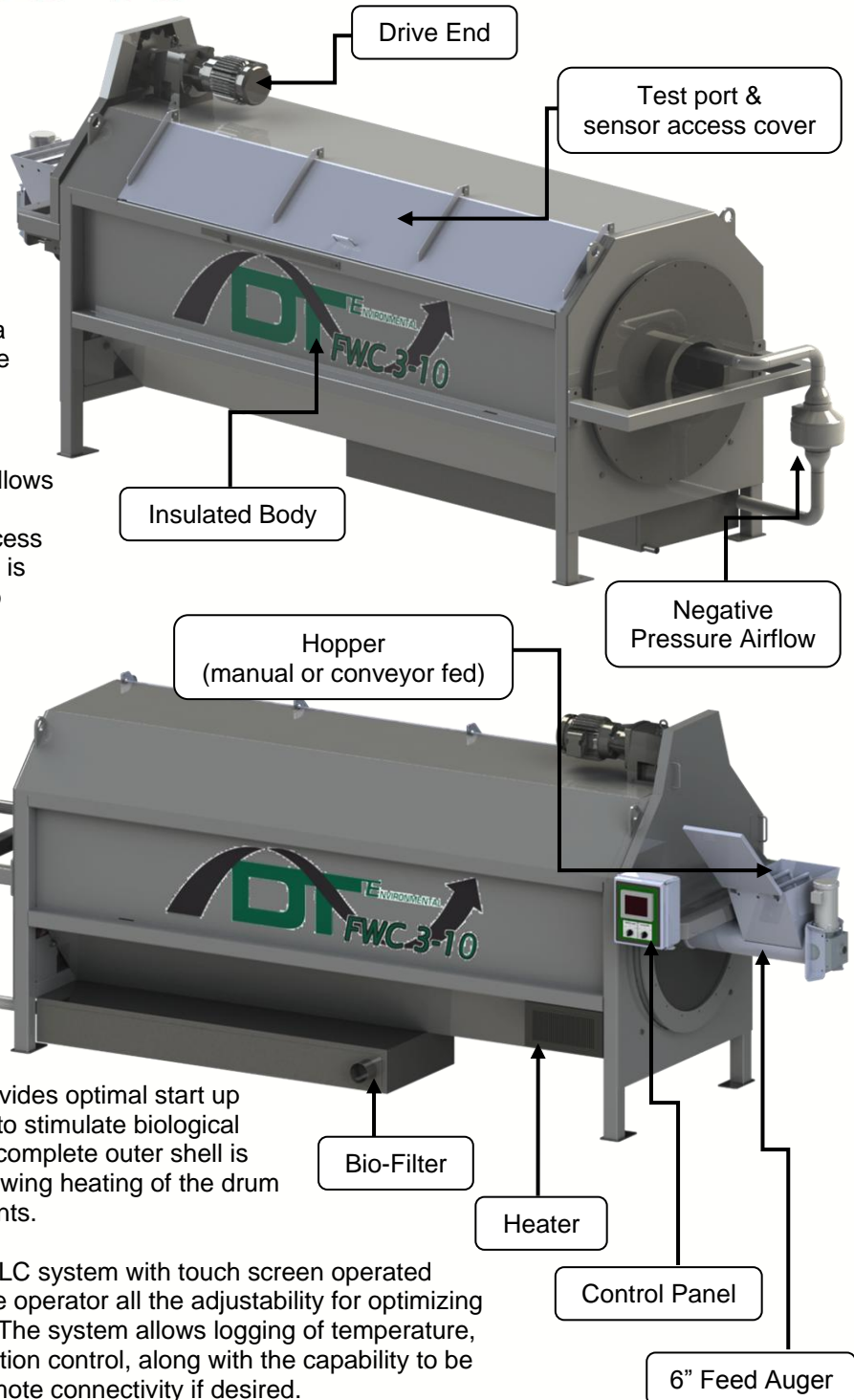

Heater – Provides optimal start up temperature to stimulate biological activity. The complete outer shell is insulated allowing heating of the drum and its contents.

PLC – The PLC system with touch screen operated HMI gives the operator all the adjustability for optimizing the process. The system allows logging of temperature, speed of rotation control, along with the capability to be set up for remote connectivity if desired.



Summary of Manufacturing Specifications

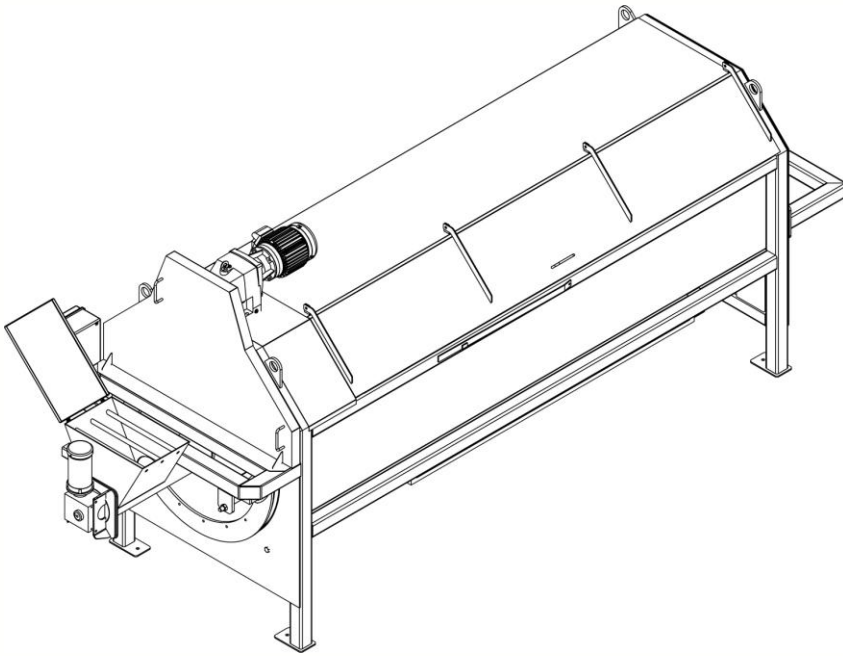

- 3" Stainless steel tubular frame construction
- Solid nylon idler wheels with sealed SS bearings
- Corrosion resistant drive chain
- Low horsepower operation
- SS in-feed auger

Equipment Footprint

